

TECHNICAL DATA

- (1) AIR INLET
- (2) CABLE ACCESS DOOR FOR 600V/480V
- (3) FUEL TANK - 4700 LTRS
- (4) FUEL FILLER
- (5) PERSONNEL ENTRANCE DOOR
- (6) SWITCHGEAR
- (7) DOOR ROOF AIR INLET
- (8) LIGHTS
- (9) GENERATOR
- (10) MUFFLER
- (11) ENGINE
- (12) FAN
- (13) RADIATOR
- (14) EXHAUST
- (15) AIR OUTLET
- (16) TRANSFORMER
- (17) FUEL/WATER SEPARATORS
- (18) BATTERIES
- (19) FUEL TRANSFER PUMP
- (20) CONTROL PANEL FOR THE FUEL TRANSFER SYSTEM
- (21) OUTSIDE DOOR FOR THE FUEL FILLER (OPTION)
- (22) REAR DOORS
- (23) CABLE ACCESS DOORS FOR 600V & 480V

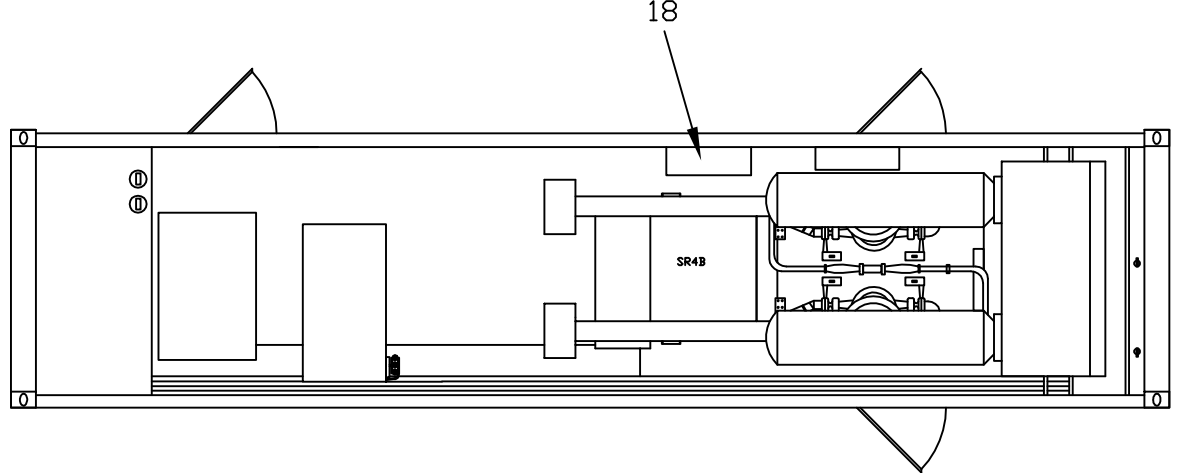
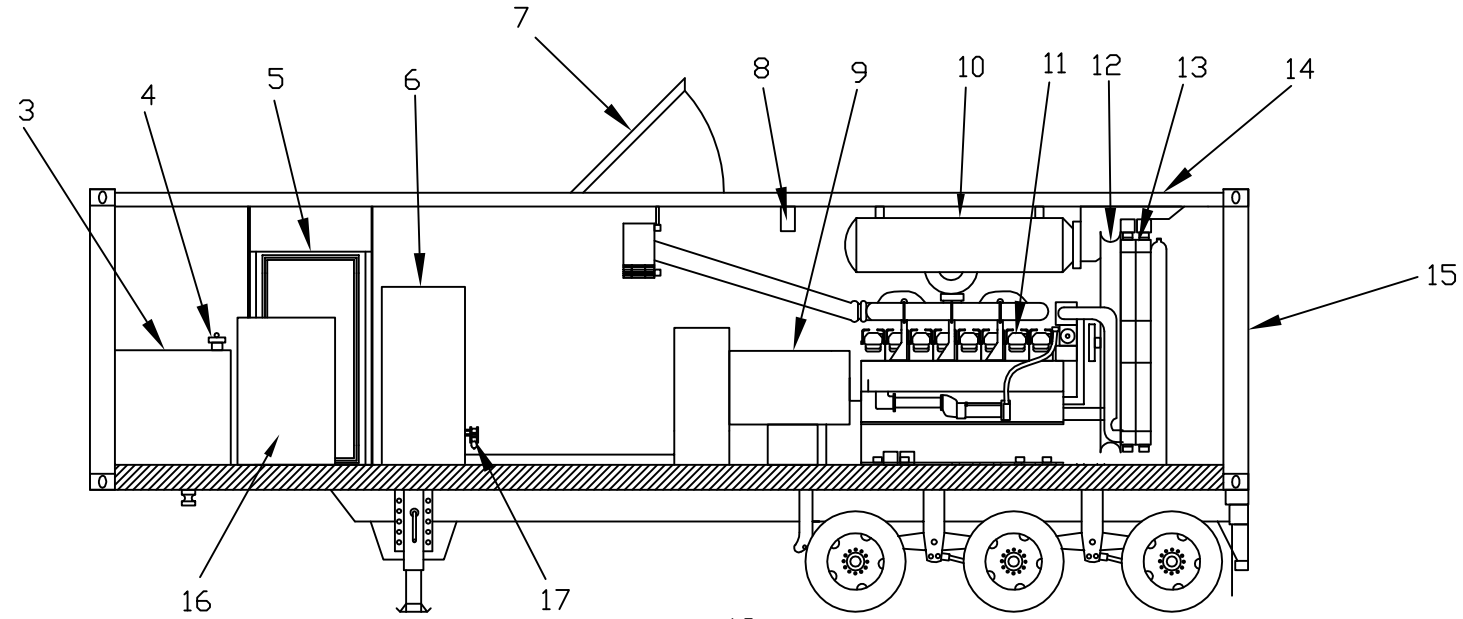

GENERATOR SET	POWER	VOLTAGE	CURRENT PRIME @ 0.8PF	CURRENT STBY @ 0.8PF	FREQUENCY	FUEL TANK CAPACITY	FUEL CONSUMPTION (75% LOAD)	FUEL CONSUMPTION (100% LOAD)
L.M.33	1750KW	600V/480V	1900A/2400A	2100A/2600A	60 HZ	5200 LITERS	378.1 L/HR	504.7 L/HR

1E2733 DRAWING-AUTOCAD
 1E0011 INTRP & TOL
 SPEC. NO. NAME
 DRN
 CHK
 APPD
 SCALE
 SHEET 1 01AUG06 DATE

 INSTRUCTION-SVGR
 600V/480V